

Technical specifications

LB110 (L-Bracket)

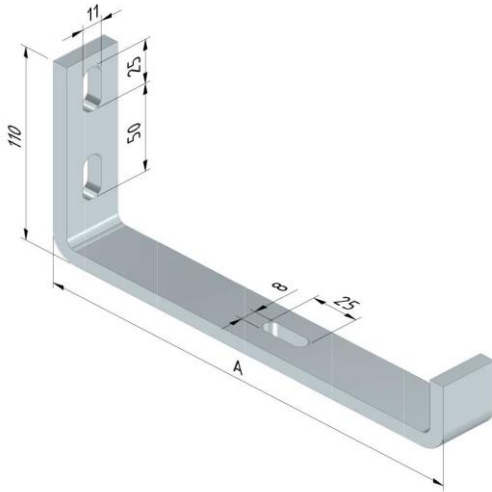

Finishing:		Electro galvanized						
Product	Number	Height (mm)	Width (mm)	Length (mm)	Dim A (mm)	Fmax (kN)	Unit	Packaging (unit)
LB110-075-EG	17101	110	75	0	100	0,45	ST	10
LB110-100-EG	17102	110	100	0	125	0,45	ST	10
LB110-150-EG	17103	110	150	0	175	0,45	ST	10
LB110-200-EG	17104	110	200	0	225	0,45	ST	10
LB110-300-EG	17105	110	300	0	330	0,45	ST	10
LB110-400-EG	17106	110	400	0	430	0,45	ST	10

Finishing:		Duplex						
Product	Number	Height (mm)	Width (mm)	Length (mm)	Dim A (mm)	Fmax (kN)	Unit	Packaging (unit)
LB110-075-CO	14298	100	75	0	100		ST	0
LB110-100-CO	14299	100	100	0	125		ST	0
LB110-150-CO	14300	100	150	0	175		ST	0
LB110-200-CO	14301	100	200	0	229		ST	0
LB110-300-CO	17099	110	300	0	330	0,45	ST	10
LB110-400-CO	17100	110	400	0	430	0,45	ST	10

Finishing:		Dipped galvanized						
Product	Number	Height (mm)	Width (mm)	Length (mm)	Dim A (mm)	Fmax (kN)	Unit	Packaging (unit)
LB110-075-DG	14294	100	75	0	100	0,45	ST	0
LB110-100-DG	14295	100	100	0	125	0,45	ST	10
LB110-150-DG	14296	100	150	0	175	0,45	ST	10
LB110-200-DG	14297	100	200	0	229	0,45	ST	10
LB110-300-DG	17097	110	300	0	100	0,45	ST	10
LB110-400-DG	17098	110	400	0	430	0,45	ST	10

Mounting instructions:

-

Load capacity:

Standard: IEC61537

Max. load: see table

Load diagram: -

Information:

Coupler: -

Equipotential bonding: IEC61537

EC declaration: EC directive 2014/35/EU (Low voltage) as modified by directive 93/68/EEC (CE marking)

EG

Electrolytically galvanized (EN ISO 2081) EG (electrogalvanized)

Electrolytically galvanized products are mostly used in places where limited chemical contamination is likely, for example, in offices, industrial buildings, covered parking lots, etc.

Electrogalvanizing differs from hot-dip galvanizing in that the zinc coating, in this case, is built up by electrolysis. With this technique, there are no thermal influences on the steel, so no layers of alloy will form. Also, the coating thicknesses of 6-8µm (micron) are more limited compared to hot-dip galvanizing.

Prior to the galvanizing, the steel sheet goes through several pre-treatment steps so as to ensure optimal adhesion (degreasing steps, pickling, a brief acid dip, multiple rinsing,....) After the galvanizing proper, the zinc coating receives a passivating- and dichromate coat, followed by a rinsing with demi-water. The advantages of electrogalvanizing are, among other things: no thermal deformation (so ideal for assembly parts), an attractive, uniform and perfectly smooth, high-gloss finish with good electrical conductivity, no runs in the paintwork or zinc jags.

DU

Duplex coats DU

For applications where a very high corrosion resistance is required, such as the petrochemical industry or maritime applications, we advise our customers to use a duplex coating. A duplex coating is composed of a hot-dip galvanizing, followed by a powder coating (in two coats or one). Research has showed that galvanized parts with an (epoxy) powder coating, afford corrosion resistance that is up to 2.5 times higher than the sum of the wear life of both systems separately.

For example: the wear life of hot-dip galvanizing is 10 years while that of an epoxy coating is 5 years. So, in combination, this gives a wear life of up to 37 years. Usually, the added cost of a duplex coating is easily outweighed by the cost price of regularly recurring maintenance every few years. (see underneath 'hot-dip galvanizing').

DG

Hot-dip galvanized (EN ISO 1461) DG (dipped-galvanised)

Whenever cable support systems are exposed to the elements and/or caustic substances (such as petrochemical applications), they are given an additional treatment in the form of hot-dip galvanizing.

Hot-dip galvanizing is a materials science process designed to render the steel non-corroding. If this coating is breached, the zinc will act as a sacrificial anode, so that the iron is protected by the zinc (aka cathodic protection). During galvanization, three alloys are formed: an iron-zinc alloy, a zinc-iron alloy and also a zinc alloy. The pre-treatment of the steel is crucially important in order to achieve a good bond.

The following process steps are involved: degreasing, rinsing, pickling, re-rinsing, fluxing, drying and hot-dipping. The coating thickness depends on the steel composition, the material thickness and the time spent in the zinc bath. In the galvanizing standard NEN-EN-ISO 1461, the minimum coating thickness are prescribed (as shown in following overview), just as the zinc shrinkage per year which will depend on environmental factors (see table entitled 'Corrosion classes'). In addition, the zinc coating forms an excellent substrate for other post-treatments, such as applying a powder coating and coats of paint (better known as the duplex system).

An added advantage of hot-dip galvanizing is that along the edges and pointy bits, where objects are usually extra susceptible to corrosion, the zinc coating is thicker because of the behaviour of the liquid.

Minimum thicknesses of the zinc coating according to ISO 1461

- Using the hot-dip method

Material thickness ≥ 6 mm = min. zinc coating thickness (average) 85 μ m

Material thickness ≥ 3 mm to < 6 mm = min. zinc coating thickness (average) 70 μ m

Material thickness $\geq 1,5$ mm to < 3 mm = min. zinc coating thickness (average) 55 μ m

Material thickness $< 1,5$ mm = min. zinc coating thickness (average) 45 μ m

- Using the drum method

Material thickness ≥ 3 mm = min. zinc coating thickness (average) 55 μ m

Material thickness < 3 mm = min. zinc coating thickness (average) 45 μ m

Field of application according to resistance against corrosion:

Corrosion classes according EN ISO 12994

Corrosion class	Atmospheric corrosion	Indoor environment	Outdoor environment	Surface treatments
C1	$< 0,1\mu\text{m}$	Heated buildings with neutral atmospheres: offices, shops, schools, hotels.		Electro-galvanised (EG) EN ISO 2081
C2	0,1 - 0,7 μm	Unheated buildings where condensation may occur: sports halls, warehouses, shops.	Rural areas. Atmosphere with low impurities.	Pre-galvanised (PG) EN 10327 – EN 10143
C3	0,7 - 2 μm	Production facilities with high moisture levels and some air impurities due to industrial processes: production plants.	City and industrial atmosphere, some impurities, coastal areas with low salt loads.	Dipped-galvanised (DG) EN ISO 1461
C4	2 - 4 μm	Production facilities with high moisture levels and high air impurities due to industrial processes: swimming pools, Chemical industry.	Industrial areas and coastal areas with low salt load.	Dipped-galvanised (DG) EN ISO 1461 Polyester coating (CO) EN ISO 12944
C5-I	4 - 8 μm	Polyester coating (CO)	Industrial areas with high moisture level and aggressive atmosphere.	Duplex (DU) (Dipped galvanised + Polyester coating) Stainless steel AISI 316L
C5-M	4 - 8 μm	EN ISO 12944	Coastal or offshore areas with salt load.	Duplex (DU) (Dipped galvanised + Polyester coating)

Classification for resistance against corrosion according to IEC61537

Class	Reference- Material and Finish
0(a)	None
1	Electroplated to a minimum thickness of 5 µm
2	Electroplated to a minimum thickness of 12 µm
3	Pre-galvanised to grade 275 to EN 10327 and EN 10326
4	Pre-galvanised to grade 350 to EN 10327 and EN 10326
5	Post-galvanised to a zinc mean coating thickness (minimum) of 45 µm according to ISO 1461 for zinc thickness only
6	Post-galvanised to a zinc mean coating thickness (minimum) of 55 µm according to ISO 1461 for zinc thickness only
7	Post-galvanised to a zinc mean coating thickness (minimum) of 70 µm according to ISO 1461 for zinc thickness only
8	Post-galvanised to a zinc mean coating thickness (minimum) of 85 µm according to ISO 1461 for zinc thickness only (usually high silicon steel)
9A	Stainless steel manufactured to ASTM: A 240/A 240M – 95a designation S30400 or EN 10088 grade 1-4301 without a post-treatment (b)
9B	Stainless steel manufactured to ASTM: A 240/A 240M – 95a designation S31603 or EN 10088 grade 1-4404 without a post-treatment (b)
9C	Stainless steel manufactured to ASTM: A 240/A 240M – 95a designation S30400 or EN 10088 grade 1-4301 with a post-treatment (b)
9D	Stainless steel manufactured to ASTM: A 240/A 240M – 95a designation S31603 or EN 10088 grade 1-4404 with a post-treatment (b)
(a) For materials which have no declared corrosion resistance classification.	
(b) The post-treatment process is used to improve the protection against crevice crack corrosion and the contamination by other steels.	