

## Technical specifications

### CB130 (C-Bracket)

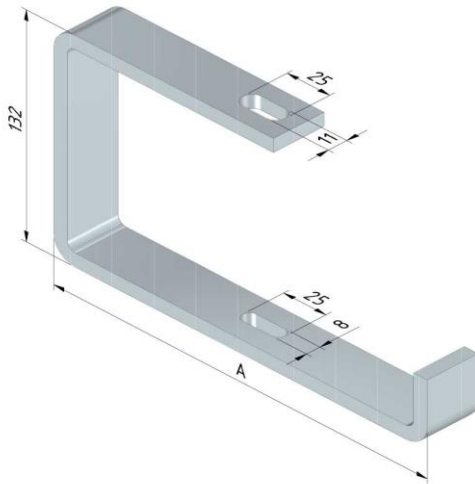

Finishing:		Electro galvanized						
Product	Number	Height (mm)	Width (mm)	Length (mm)	Dim A (mm)	Fmax (kN)	Unit	Packaging (unit)
CB130-075-EG	17083	130	75	0	100	0,45	ST	10
CB130-100-EG	17084	130	100	0	125	0,45	ST	10
CB130-150-EG	17085	130	150	0	175	0,45	ST	10
CB130-200-EG	17086	130	200	0	225	0,45	ST	10
CB130-300-EG	17087	130	300	0	330	0,45	ST	10
CB130-400-EG	17088	130	400	0	430	0,45	ST	10

Finishing:		Duplex						
Product	Number	Height (mm)	Width (mm)	Length (mm)	Dim A (mm)	Fmax (kN)	Unit	Packaging (unit)
CB130-075-DU	13161	130	75	0	100	0,45	ST	10
CB130-100-DU	13162	130	100	0	125	0,45	ST	10
CB130-150-DU	13163	130	150	0	175	0,45	ST	10
CB130-200-DU	13164	130	200	0	225	0,45	ST	10
CB130-300-DU	13165	130	300	0	330	0,45	ST	10
CB130-400-DU	13166	130	400	0	430	0,45	ST	10

Finishing:		Dipped galvanized						
Product	Number	Height (mm)	Width (mm)	Length (mm)	Dim A (mm)	Fmax (kN)	Unit	Packaging (unit)
CB130-075-DG	13155	130	75	0	100	0,45	ST	10
CB130-100-DG	13156	130	100	0	125	0,45	ST	10
CB130-150-DG	13157	130	150	0	175	0,45	ST	10
CB130-200-DG	13158	130	200	0	225	0,45	ST	10
CB130-300-DG	13159	130	300	0	330	0,45	ST	10
CB130-400-DG	13160	130	400	0	430	0,45	ST	10

Finishing:		Coated						
Product	Number	Height (mm)	Width (mm)	Length (mm)	Dim A (mm)	Fmax (kN)	Unit	Packaging (unit)
CB130-075-CO	17141	130	75	0	100	0,45	ST	10
CB130-100-CO	17142	130	100	0	125	0,45	ST	10
CB130-150-CO	17143	130	150	0	175	0,45	ST	10
CB130-200-CO	17144	130	200	0	225	0,45	ST	10

CB130-300-CO	17145	130	300	0	330	0,45	ST	10
CB130-400-CO	17146	130	400	0	430	0,45	ST	10

Mounting instructions:

-

Load capacity:

Standard: IEC61537

Max. load: see table

Load diagram: -

Information:

Coupler: -

Equipotential bonding: IEC61537

EC declaration: EC directive 2014/35/EU (Low voltage) as modified by directive 93/68/EEC (CE marking)

EG

Electrolytically galvanized (EN ISO 2081) EG (electrogalvanized)

Electrolytically galvanized products are mostly used in places where limited chemical contamination is likely, for example, in offices, industrial buildings, covered parking lots, etc.

Electrogalvanizing differs from hot-dip galvanizing in that the zinc coating, in this case, is built up by electrolysis. With this technique, there are no thermal influences on the steel, so no layers of alloy will form. Also, the coating thicknesses of 6-8µm (micron) are more limited compared to hot-dip galvanizing.

Prior to the galvanizing, the steel sheet goes through several pre-treatment steps so as to ensure optimal adhesion (degreasing steps, pickling, a brief acid dip, multiple rinsing,....) After the galvanizing proper, the zinc coating receives a passivating- and dichromate coat, followed by a rinsing with demi-water. The advantages of electrogalvanizing are, among other things: no thermal deformation (so ideal for assembly parts), an attractive, uniform and perfectly smooth, high-gloss finish with good electrical conductivity, no runs in the paintwork or zinc jags.

DU

Duplex coats DU

For applications where a very high corrosion resistance is required, such as the petrochemical industry or maritime applications, we advise our customers to use a duplex coating. A duplex coating is composed of a hot-dip galvanizing, followed by a powder coating (in two coats or one). Research has showed that galvanized parts with an (epoxy) powder coating, afford corrosion resistance that is up to 2.5 times higher than the sum of the wear life of both systems separately.

For example: the wear life of hot-dip galvanizing is 10 years while that of an epoxy coating is 5 years. So, in combination, this gives a wear life of up to 37 years. Usually, the added cost of a duplex coating is easily outweighed by the cost price of regularly recurring maintenance every few years. ( see underneath 'hot-dip galvanizing').

DG

Hot-dip galvanized (EN ISO 1461) DG (dipped-galvanised)

Whenever cable support systems are exposed to the elements and/or caustic substances (such as petrochemical applications), they are given an additional treatment in the form of hot-dip galvanizing.

Hot-dip galvanizing is a materials science process designed to render the steel non-corroding. If this coating is breached, the zinc will act as a sacrificial anode, so that the iron is protected by the zinc (aka cathodic protection). During galvanization, three alloys are formed: an iron-zinc alloy, a zinc-iron alloy and also a zinc alloy. The pre-treatment of the steel is crucially important in order to achieve a good bond.

The following process steps are involved: degreasing, rinsing, pickling, re-rinsing, fluxing, drying and hot-dipping. The coating thickness depends on the steel composition, the material thickness and the time spent in the zinc bath. In the galvanizing standard NEN-EN-ISO 1461, the minimum coating thickness are prescribed (as shown in following overview), just as the zinc shrinkage per year which will depend on environmental factors (see table entitled 'Corrosion classes'). In addition, the zinc coating forms an excellent substrate for other post-treatments, such as applying a powder coating and coats of paint (better known as the duplex system).

An added advantage of hot-dip galvanizing is that along the edges and pointy bits, where objects are usually extra susceptible to corrosion, the zinc coating is thicker because of the behaviour of the liquid.

Minimum thicknesses of the zinc coating according to ISO 1461

- Using the hot-dip method

Material thickness  $\geq 6$  mm = min. zinc coating thickness (average) 85 $\mu$ m

Material thickness  $\geq 3$  mm to  $< 6$  mm = min. zinc coating thickness (average) 70 $\mu$ m

Material thickness  $\geq 1,5$  mm to  $< 3$  mm = min. zinc coating thickness (average) 55 $\mu$ m

Material thickness  $< 1,5$  mm = min. zinc coating thickness (average) 45 $\mu$ m

- Using the drum method

Material thickness  $\geq 3$  mm = min. zinc coating thickness (average) 55 $\mu$ m

Material thickness  $< 3$  mm = min. zinc coating thickness (average) 45 $\mu$ m

## CO

Polyester powder coating CO (coated)

Polyester coats will be used in moderate environments where the aesthetic aspect and sustainability must go hand in hand. The distinctive property of a polyester coating is its resistance to discoloration due to sunlight.

If used in a harsher environment, it is strongly recommended to apply an epoxy coating; this is less porous and therefore more resistant to chemicals. The disadvantage of an epoxy coating, however, is the rapid discoloration. If you want the best of both worlds, use an epoxy primer with a polyester top coat.

Just as with all the treatment techniques mentioned above, a thorough pre-treatment is crucial here too.

Depending on the base material, one will, in this case, degrease, rinse, pickle, rinse again, apply a conversion coat (e.g. chrome), rinse again, rinse with demi-water and/or dry.

Field of application according to resistance against corrosion:

**Corrosion classes according EN ISO 12994**

Corrosion class	Atmospheric corrosion	Indoor environment	Outdoor environment	Surface treatments
C1	<0,1µm	Heated buildings with neutral atmospheres: offices, shops, schools, hotels.		Electro-galvanised (EG) EN ISO 2081
C2	0,1 - 0,7µm	Unheated buildings where condensation may occur: sports halls, warehouses, shops.	Rural areas. Atmosphere with low impurities.	Pre-galvanised (PG) EN 10327 – EN 10143
C3	0,7 - 2µm	Production facilities with high moisture levels and some air impurities due to industrial processes: production plants.	City and industrial atmosphere, some impurities, coastal areas with low salt loads.	Dipped-galvanised (DG) EN ISO 1461
C4	2 - 4µm	Production facilities with high moisture levels and high air impurities due to industrial processes: swimming pools, Chemical industry.	Industrial areas and coastal areas with low salt load.	Dipped-galvanised (DG) EN ISO 1461 Polyester coating (CO) EN ISO 12944
C5-I	4 - 8µm	Polyester coating (CO)	Industrial areas with high moisture level and aggressive atmosphere.	Duplex (DU) (Dipped galvanised + Polyester coating) Stainless steel AISI 316L
C5-M	4 - 8µm	EN ISO 12944	Coastal or offshore areas with salt load.	Duplex (DU) (Dipped galvanised + Polyester coating)

**Classification for resistance against corrosion according to IEC61537**

Class	Reference- Material and Finish
0(a)	None
1	Electroplated to a minimum thickness of 5 µm
2	Electroplated to a minimum thickness of 12 µm
3	Pre-galvanised to grade 275 to EN 10327 and EN 10326
4	Pre-galvanised to grade 350 to EN 10327 and EN 10326
5	Post-galvanised to a zinc mean coating thickness (minimum) of 45 µm according to ISO 1461 for zinc thickness only
6	Post-galvanised to a zinc mean coating thickness (minimum) of 55 µm according to ISO 1461 for zinc thickness only
7	Post-galvanised to a zinc mean coating thickness (minimum) of 70 µm according to ISO 1461 for zinc thickness only
8	Post-galvanised to a zinc mean coating thickness (minimum) of 85 µm according to ISO 1461 for zinc thickness only (usually high silicon steel)
9A	Stainless steel manufactured to ASTM: A 240/A 240M – 95a designation S30400 or EN 10088 grade 1-4301 without a post-treatment (b)
9B	Stainless steel manufactured to ASTM: A 240/A 240M – 95a designation S31603 or EN 10088 grade 1-4404 without a post-treatment (b)
9C	Stainless steel manufactured to ASTM: A 240/A 240M – 95a designation S30400 or EN 10088 grade 1-4301 with a post-treatment (b)
9D	Stainless steel manufactured to ASTM: A 240/A 240M – 95a designation S31603 or EN 10088 grade 1-4404 with a post-treatment (b)
(a) For materials which have no declared corrosion resistance classification.	
(b) The post-treatment process is used to improve the protection against crevice crack corrosion and the contamination by other steels.	