

# Technical specifications

## CTMI60 (Cable tray machine interl. End)

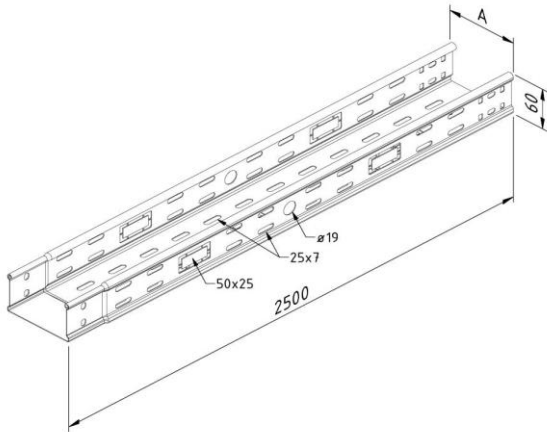

Finishing:		Pre-galvanized						
Product	Number	Height (mm)	Width (mm)	Length (mm)	Dim A (mm)	Fmax (kN)	Unit	Packaging (unit)
CTMI60-050-10-25PG	13148	60	50	2500	50		M	2,5
CTMI60-100-10-25PG	13149	60	100	2500	100		M	2,5

Finishing:		Dipped galvanized						
Product	Number	Height (mm)	Width (mm)	Length (mm)	Dim A (mm)	Fmax (kN)	Unit	Packaging (unit)
CTMI60-050-10-25DG	13150	60	50	2500			M	2,5
CTMI60-100-10-25DG	13151	60	100	2500			M	2,5

Finishing:		Coated						
Product	Number	Height (mm)	Width (mm)	Length (mm)	Dim A (mm)	Fmax (kN)	Unit	Packaging (unit)
CTMI60-050-10-25CO	13152	60	50	2500			M	2,5
CTMI60-100-10-25CO	13153	60	100	2500			M	2,5

Mounting instructions:

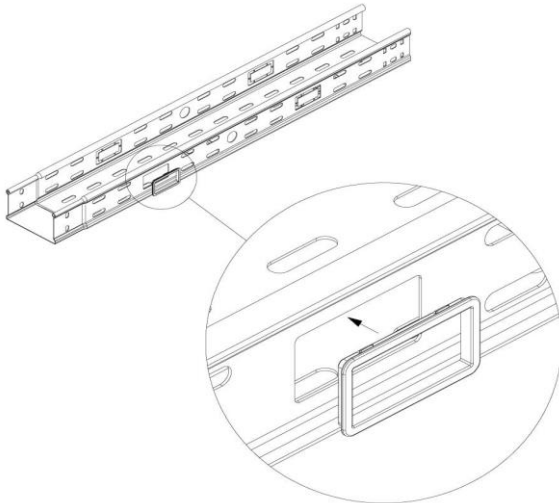

**Load capacity:**

Standard: -

Max. load: -

Load diagram: -

**Information:**

Coupler: BN06-10-EG

Equipotential bonding: IEC61537

EC declaration: EC directive 2006/95/EC (Low voltage) as modified by directive 93/68/EEC (CE marking)

**PG**

**Sendzimir galvanized (EN 10143) PG (pre-galvanized)**

Products made of Sendzimir (pre-galvanized) or continuous hot-dip galvanized steel sheet and coils are mostly used wherever limited chemical contamination is likely, for example, in offices, industrial buildings, covered parking lots, etc.

Characteristic of this steel type is that – prior to mechanical deformation – it is given a zinc coating by means of a continuous dipping process. This zinc coating is easily deformed. A cathodic action occurs on cut surfaces (up to 1.5mm) that protects against oxidation.

First, the steel is chemical cleaned and roughened in order to achieve a good bond. After the dipping process, the surplus zinc is blown off and one obtains an extra passivating coat (an ultra-thin protective coat) to prevent oxidation of the zinc coating (white rust). The coating thickness is usually expressed in g/m<sup>2</sup>. The most deployed type of Sendzimir steel is Z 275 = 275g/m<sup>2</sup> (weighed on both sides), this corresponds to 18-20 µm (micron).

Sendzimir galvanized steel sourced from modern galvanizing lines has, in general, a uniform, shiny appearance. The previous, common flowery surface is scarcely seen these days. This effect is obtained under the influence of lead but has no effect on the quality of the coating. The use of lead was banned due to the ever more stringent environmental standards.

**DG**

Hot-dip galvanized (EN ISO 1461) DG (dipped-galvanised)

Whenever cable support systems are exposed to the elements and/or caustic substances (such as petrochemical applications), they are given an additional treatment in the form of hot-dip galvanizing.

Hot-dip galvanizing is a materials science process designed to render the steel non-corroding. If this coating is breached, the zinc will act as a sacrificial anode, so that the iron is protected by the zinc (aka cathodic protection). During galvanization, three alloys are formed: an iron-zinc alloy, a zinc-iron alloy and also a zinc alloy. The pre-treatment of the steel is crucially important in order to achieve a good bond.

The following process steps are involved: degreasing, rinsing, pickling, re-rinsing, fluxing, drying and hot-dipping. The coating thickness depends on the steel composition, the material thickness and the time spent in the zinc bath. In the galvanizing standard NEN-EN-ISO 1461, the minimum coating thickness are prescribed (as shown in following overview), just as the zinc shrinkage per year which will depend on environmental factors (see table entitled 'Corrosion classes'). In addition, the zinc coating forms an excellent substrate for other post-treatments, such as applying a powder coating and coats of paint (better known as the duplex system).

An added advantage of hot-dip galvanizing is that along the edges and pointy bits, where objects are usually extra susceptible to corrosion, the zinc coating is thicker because of the behaviour of the liquid.

Minimum thicknesses of the zinc coating according to ISO 1461

- Using the hot-dip method

Material thickness  $\geq 6$  mm = min. zinc coating thickness (average) 85 $\mu$ m

Material thickness  $\geq 3$  mm to  $< 6$  mm = min. zinc coating thickness (average) 70 $\mu$ m

Material thickness  $\geq 1,5$  mm to  $< 3$  mm = min. zinc coating thickness (average) 55 $\mu$ m

Material thickness  $< 1,5$  mm = min. zinc coating thickness (average) 45 $\mu$ m

- Using the drum method

Material thickness  $\geq 3$  mm = min. zinc coating thickness (average) 55 $\mu$ m

Material thickness  $< 3$  mm = min. zinc coating thickness (average) 45 $\mu$ m

### CO

Polyester powder coating CO (coated)

Polyester coats will be used in moderate environments where the aesthetic aspect and sustainability must go hand in hand. The distinctive property of a polyester coating is its resistance to discoloration due to sunlight.

If used in a harsher environment, it is strongly recommended to apply an epoxy coating; this is less porous and therefore more resistant to chemicals. The disadvantage of an epoxy coating, however, is the rapid discoloration. If you want the best of both worlds, use an epoxy primer with a polyester top coat.

Just as with all the treatment techniques mentioned above, a thorough pre-treatment is crucial here too.

Depending on the base material, one will, in this case, degrease, rinse, pickle, rinse again, apply a conversion coat (e.g. chrome), rinse again, rinse with demi-water and/or dry.

### Field of application according to resistance against corrosion:

Corrosion class	Atmospheric corrosion	Indoor environment	Outdoor environment	Surface treatments
C1	$< 0,1\mu\text{m}$	Heated buildings with neutral atmospheres: offices, shops, schools, hotels.		Electro-galvanised (EG) EN ISO 2081
C2	0,1 - 0,7 $\mu\text{m}$	Unheated buildings where condensation may occur: sports halls, warehouses, shops.	Rural areas. Atmosphere with low impurities.	Pre-galvanised (PG) EN 10327 – EN 10143
C3	0,7 - 2 $\mu\text{m}$	Production facilities with high moisture levels and some air impurities due to industrial processes: production plants.	City and industrial atmosphere, some impurities, coastal areas with low salt loads.	Dipped-galvanised (DG) EN ISO 1461
C4	2 - 4 $\mu\text{m}$	Production facilities with high moisture levels and high air impurities due to industrial processes: swimming pools, Chemical industry.	Industrial areas and coastal areas with low salt load.	Dipped-galvanised (DG) EN ISO 1461 Polyester coating (CO) EN ISO 12944
C5-I	4 - 8 $\mu\text{m}$	Polyester coating (CO)	Industrial areas with high moisture level and aggressive atmosphere.	Duplex (DU) [Dipped galvanised + Polyester coating] Stainless steel AISI 316L
C5-M	4 - 8 $\mu\text{m}$	EN ISO 12944	Coastal or offshore areas with salt load.	Duplex (DU) [Dipped galvanised + Polyester coating] Stainless steel AISI 316L