

Technical specifications

FD-ACC-RB-3C (Floor duct rising bend 3 comp.)

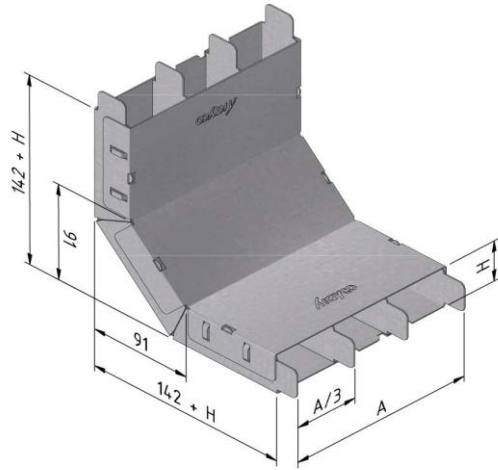

Finishing:		Pre-galvanized						
Product	Number	Height (mm)	Width (mm)	Length (mm)	Dim A (mm)	Fmax (kN)	Unit	Packaging (unit)
FS-FD-RB28-170-3C-PG	15736	28	170	0	170		ST	1
FS-FD-RB28-250-3C-PG	15737	28	250	0	250		ST	1
FS-FD-RB28-350-3C-PG	15738	28	350	0	350		ST	1
FS-FD-RB38-170-3C-PG	15739	38	170	0	170		ST	1
FS-FD-RB38-250-3C-PG	15740	38	250	0	250		ST	1
FS-FD-RB38-350-3C-PG	15741	38	350	0	350		ST	1
FS-FD-RB48-170-3C-PG	15742	48	170	0	170		ST	1
FS-FD-RB48-250-3C-PG	15743	48	250	0	250		ST	1
FS-FD-RB48-350-3C-PG	15744	48	350	0	350		ST	1

Mounting instructions:

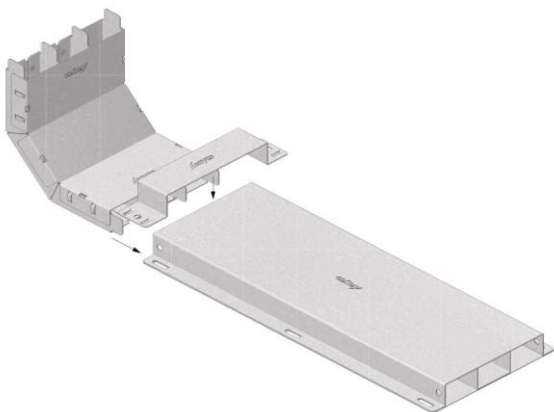

Load capacity:

Standard: -
Max. load: -
Load diagram: -

Information:

Coupler: -
Equipotential bonding: IEC61537
EC declaration: EC directive 2014/35/EU (Low voltage) as modified by directive 93/68/EEC (CE marking)

PG

Sendzimir galvanized (EN 10143) PG (pre-galvanized)

Products made of Sendzimir (pre-galvanized) or continuous hot-dip galvanized steel sheet and coils are mostly used wherever limited chemical contamination is likely, for example, in of ces, industrial buildings, covered parking lots, etc.

Characteristic of this steel type is that – prior to mechanical deformation – it is given a zinc coating by means of a continuous dipping process. This zinc coating is easily deformed. A cathodic action occurs on cut surfaces (up to 1.5mm) that protects against oxidation.

First, the steel is chemical cleaned and roughened in order to achieve a good bond. After the dipping process, the surplus zinc is blown off and one obtains an extra passivating coat (an ultra-thin protective coat) to prevent oxidation of the zinc coating (white rust). The coating thickness is usually expressed in g/m². The most deployed type of Sendzimir steel is Z 275 = 275g/m² (weighed on both sides), this corresponds to 18-20 µm (micron). Sendzimir galvanized steel sourced from modern galvanizing lines has, in general, a uniform, shiny appearance. The previous, common flowery surface is scarcely seen these days. This effect is obtained under the influence of lead but has no effect on the quality of the coating. The use of lead was banned due to the ever more stringent environmental standards.

Field of application according to resistance against corrosion:

Corrosion classes according EN ISO 12994

Corrosion class	Atmospheric corrosion	Indoor environment	Outdoor environment	Surface treatments
C1	< 0,1µm	Heated buildings with neutral atmospheres: offices, shops, schools, hotels.		Electro-galvanised (EG) EN ISO 2081
C2	0,1 - 0,7µm	Unheated buildings where condensation may occur: sports halls, warehouses, shops.	Rural areas. Atmosphere with low impurities.	Pre-galvanised (PG) EN 10327 – EN 10143
C3	0,7 - 2µm	Production facilities with high moisture levels and some air impurities due to industrial processes: production plants.	City and industrial atmosphere, some impurities, coastal areas with low salt loads.	Dipped-galvanised (DG) EN ISO 1461
C4	2 - 4µm	Production facilities with high moisture levels and high air impurities due to industrial processes: swimming pools, Chemical industry.	Industrial areas and coastal areas with low salt load.	Dipped-galvanised (DG) EN ISO 1461 Polyester coating (CO) EN ISO 12944
C5-I	4 - 8µm	Polyester coating (CO)	Industrial areas with high moisture level and aggressive atmosphere.	Duplex (DU) (Dipped galvanised + Polyester coating) Stainless steel AISI 316L
C5-M	4 - 8µm	EN ISO 12944	Coastal or offshore areas with salt load.	Duplex (DU) (Dipped galvanised + Polyester coating)

Classification for resistance against corrosion according to IEC61537

Class	Reference- Material and Finish
0(a)	None
1	Electroplated to a minimum thickness of 5 µm
2	Electroplated to a minimum thickness of 12 µm
3	Pre-galvanised to grade 275 to EN 10327 and EN 10326
4	Pre-galvanised to grade 350 to EN 10327 and EN 10326
5	Post-galvanised to a zinc mean coating thickness (minimum) of 45 µm according to ISO 1461 for zinc thickness only
6	Post-galvanised to a zinc mean coating thickness (minimum) of 55 µm according to ISO 1461 for zinc thickness only
7	Post-galvanised to a zinc mean coating thickness (minimum) of 70 µm according to ISO 1461 for zinc thickness only
8	Post-galvanised to a zinc mean coating thickness (minimum) of 85 µm according to ISO 1461 for zinc thickness only (usually high silicon steel)
9A	Stainless steel manufactured to ASTM: A 240/A 240M – 95a designation S30400 or EN 10088 grade 1-4301 without a post-treatment (b)
9B	Stainless steel manufactured to ASTM: A 240/A 240M – 95a designation S31603 or EN 10088 grade 1-4404 without a post-treatment (b)
9C	Stainless steel manufactured to ASTM: A 240/A 240M – 95a designation S30400 or EN 10088 grade 1-4301 with a post-treatment (b)
9D	Stainless steel manufactured to ASTM: A 240/A 240M – 95a designation S31603 or EN 10088 grade 1-4404 with a post-treatment (b)
(a) For materials which have no declared corrosion resistance classification.	
(b) The post-treatment process is used to improve the protection against crevice crack corrosion and the contamination by other steels.	