

## Technical specifications

### SS-CLFI60-RFB (Rising-/Falling Bend CLFI60)

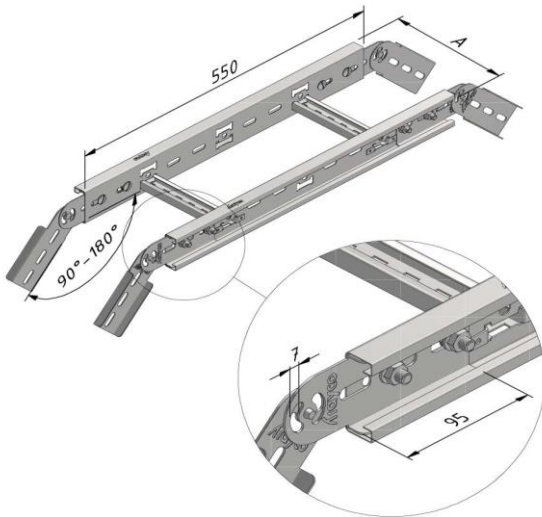

Finishing:		Stainless steel 316						
Product	Number	Height (mm)	Width (mm)	Length (mm)	Dim A (mm)	Fmax (kN)	Unit	Packaging (unit)
CLFI60-RFB-0200-SS316	18188	60	200	0	200		ST	1
CLFI60-RFB-0300-SS316	18189	60	300	0	300		ST	1
CLFI60-RFB-0400-SS316	18190	60	400	0	400		ST	1
CLFI60-RFB-0500-SS316	18191	60	500	0	500		ST	1
CLFI60-RFB-0600-SS316	18192	60	600	0	600		ST	1
RHB06-10-SS316	12877	0	6	10	M6		ST	200
RHB06-20-SS316	12785	0	6	20	M6		ST	200
RHB08-16-SS316	18300	0	8	16	M8		ST	200

#### Mounting instructions:

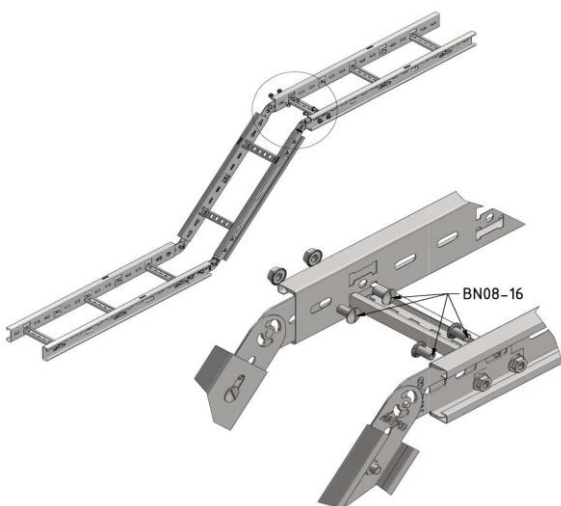

#### Load capacity:

Standard: -

Max. load: -

Load diagram: -

Information:

Coupler: BN08-16

Equipotential bonding: IEC61537

EC declaration: EC directive 2014/35/EU (Low voltage) as modified by directive 93/68/EEC (CE marking)

SS316

Stainless steel (1.4404) AISI 316L

Adding chrome(±13%) to the iron creates a certain sheen and the metal becomes more corrosion-resistant.

The advantage, compared to other protective coatings, is that it's not a one-off surface protection. In fact, the stainless steel (or rather the chrome) forms a thin, invisible layer of chromium oxide whenever it comes into contact with oxygen: the oxide film.

This thin layer protects the underlying stainless steel from further corrosion (oxidation). If the oxide film suffers damage, then the underlying stainless steel will be re-exposed to the oxygen in the air and the protective coat will re-form. In this way, it repairs itself whenever it gets damaged.

In certain circumstances or if the protective oxide film is damaged, the corrosion can be locally quite rapid. This is caused, among other things, by chlorides or other materials (usually iron) that lodge in the surface. Due to this contamination, pitting corrosion may occur that corrodes the stainless steel (SS). That's why, after the processing, the SS is treated, to remove all possible impurities. This is the 'pickling' stage.

As mentioned above, a passive chromium layer protects the steel and repairs itself automatically. There are, however, circumstances in which this repair does not happen. Certain process steps may disrupt the balance in such a way that the passive state disappears and an active layer is formed. This could occur during process steps such as welding, bending or machining (with removal of metal or wood), giving rise to oxygen-poor pockets and the repair fails to materialise. Consequently, the rustproof properties are lost and, if exposed to gases or liquids, corrosion will occur.

To remedy this situation, the active layer is re-converted to a passive layer (this process is known as passivating). It is usually desirable to degrease the semi-finished products and, after that, to pickle them in a mixture of nitric acid (HNO<sub>3</sub>) and hydrogen fluoride (HF), in order to remove impurities from the metal surface. This may be necessary on welded surfaces or on rotated objects for which a coolant is used.

Field of application according to resistance against corrosion:

**Corrosion classes according EN ISO 12994**

Corrosion class	Atmospheric corrosion	Indoor environment	Outdoor environment	Surface treatments
C1	<0,1µm	Heated buildings with neutral atmospheres: offices, shops, schools, hotels.		Electro-galvanised (EG) EN ISO 2081
C2	0,1 - 0,7µm	Unheated buildings where condensation may occur: sports halls, warehouses, shops.	Rural areas. Atmosphere with low impurities.	Pre-galvanised (PG) EN 10327 – EN 10143
C3	0,7 - 2µm	Production facilities with high moisture levels and some air impurities due to industrial processes: production plants.	City and industrial atmosphere, some impurities, coastal areas with low salt loads.	Dipped-galvanised (DG) EN ISO 1461
C4	2 - 4µm	Production facilities with high moisture levels and high air impurities due to industrial processes: swimming pools, Chemical industry.	Industrial areas and coastal areas with low salt load.	Dipped-galvanised (DG) EN ISO 1461 Polyester coating (CO) EN ISO 12944
C5-I	4 - 8µm	Polyester coating (CO)	Industrial areas with high moisture level and aggressive atmosphere.	Duplex (DU) (Dipped galvanised + Polyester coating) Stainless steel AISI 316L
C5-M	4 - 8µm	EN ISO 12944	Coastal or offshore areas with salt load.	Duplex (DU) (Dipped galvanised + Polyester coating)

**Classification for resistance against corrosion according to IEC61537**

Class	Reference- Material and Finish
0(a)	None
1	Electroplated to a minimum thickness of 5 µm
2	Electroplated to a minimum thickness of 12 µm
3	Pre-galvanised to grade 275 to EN 10327 and EN 10326
4	Pre-galvanised to grade 350 to EN 10327 and EN 10326
5	Post-galvanised to a zinc mean coating thickness (minimum) of 45 µm according to ISO 1461 for zinc thickness only
6	Post-galvanised to a zinc mean coating thickness (minimum) of 55 µm according to ISO 1461 for zinc thickness only
7	Post-galvanised to a zinc mean coating thickness (minimum) of 70 µm according to ISO 1461 for zinc thickness only
8	Post-galvanised to a zinc mean coating thickness (minimum) of 85 µm according to ISO 1461 for zinc thickness only (usually high silicon steel)
9A	Stainless steel manufactured to ASTM: A 240/A 240M – 95a designation S30400 or EN 10088 grade 1-4301 without a post-treatment (b)
9B	Stainless steel manufactured to ASTM: A 240/A 240M – 95a designation S31603 or EN 10088 grade 1-4404 without a post-treatment (b)
9C	Stainless steel manufactured to ASTM: A 240/A 240M – 95a designation S30400 or EN 10088 grade 1-4301 with a post-treatment (b)
9D	Stainless steel manufactured to ASTM: A 240/A 240M – 95a designation S31603 or EN 10088 grade 1-4404 with a post-treatment (b)
(a) For materials which have no declared corrosion resistance classification.	
(b) The post-treatment process is used to improve the protection against crevice crack corrosion and the contamination by other steels.	